

INSTALLATION INSTRUCTIONS

DESCRIPTION: Bed Rack Kit

PART NUMBER: B4M-F48A0-V0

MODEL: 2021+ Wolverine RMAX2



⚠ WARNING

Please read and understand these instructions completely before installation to avoid possible injury, or damage to the accessory or vehicle.

NOTICE:

Installation of this kit requires a torque wrench and should be performed by an authorized Yamaha dealer or a qualified mechanic.

WARRANTY INFORMATION:

In the United States, contact your dealer of purchase for information, fitment advice and a copy of the Yamaha Genuine Parts and Accessories Limited Warranty for this accessory.

DEALER OR INSTALLER:

These instructions contain important information for future reference and *must* be given to the customer.

Bed Rack Kit maximum load is 50 lbs. (22.6 kg) (Cargo and whip flags combined.)

PARTS LIST:

No.	Part Number	Description	Qty
--	B4M-F48A0-V0	Bed Rack Kit	--
①	*	Gear Rack	1
②	*	Left Side Support	1
③	*	Right Side Support	1
④	*	Center Support	1
⑤	*	Whip Mount	2
⑥	95817-08020	M8x20 Flanged Hex Head Bolt	6
⑦	95707-08500	M8 Flanged Hex Nut	2
⑧	92017-08020	M8x20 Button Head Screw	2
⑨	95817-06030	M6x30 Flanged Hex Head Bolt	4
⑩	*	Pinch Point Decal	2

* Part supplied with kit only and not available separately.

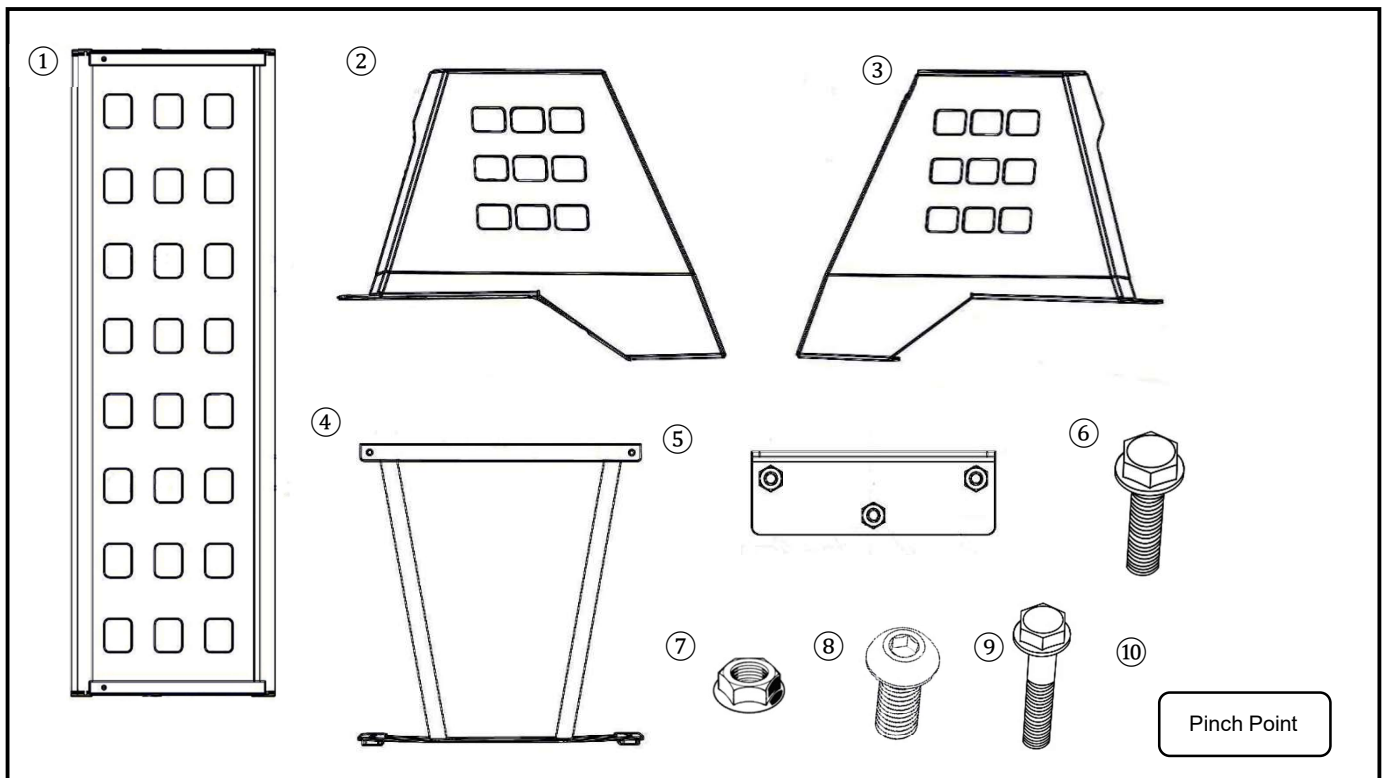

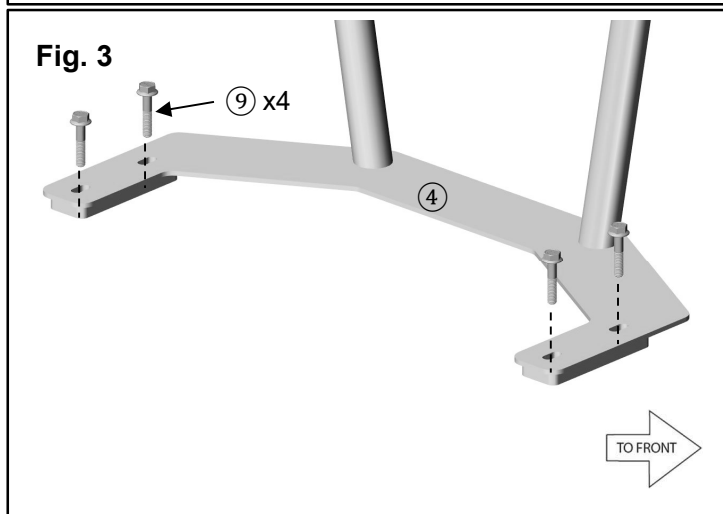
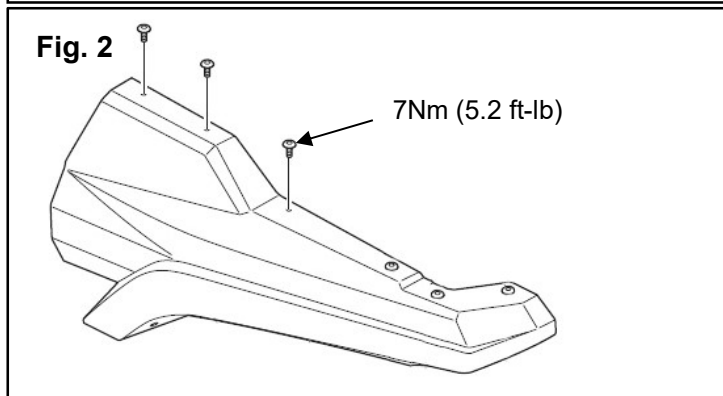
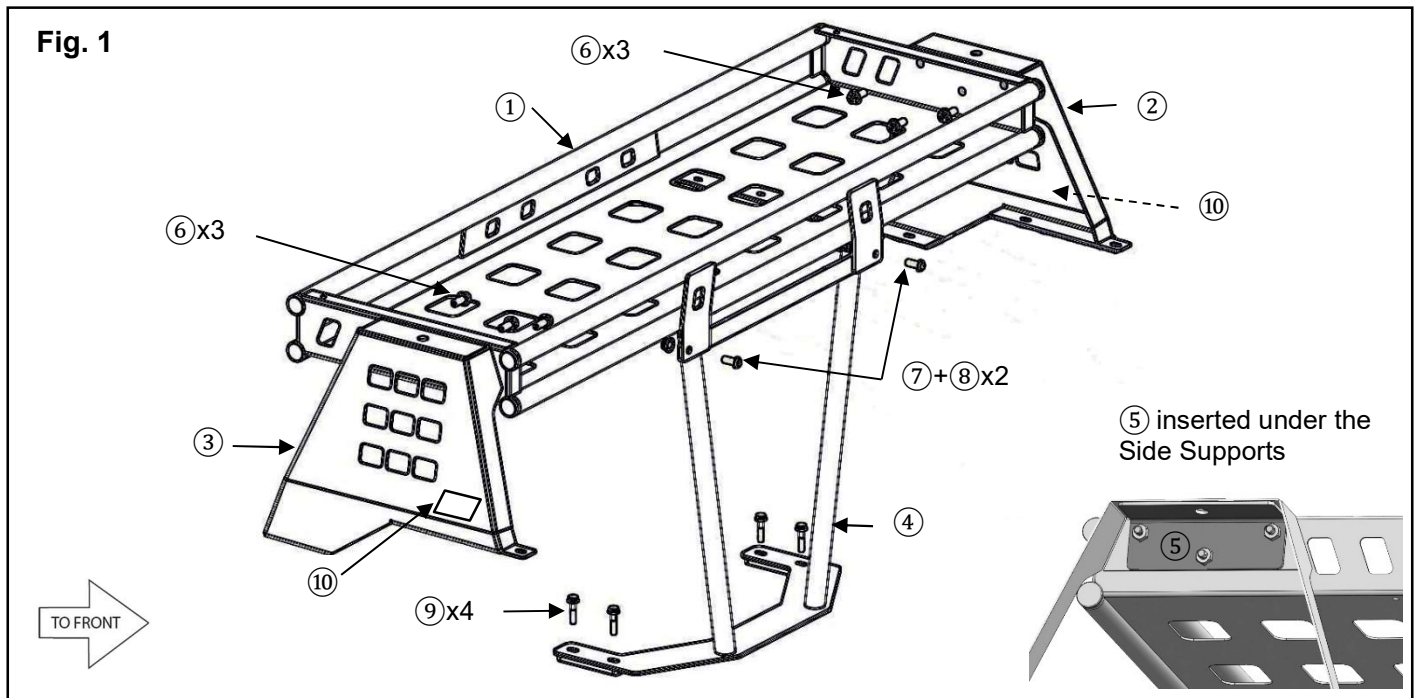

PREPARATION:

- Place the vehicle on a secure and level surface.
- Set the parking brake.
- Clean the mounting surfaces before beginning installation.

INSTALLATION:

1. Remove the stock bolts on each side of the bed. Retain for reuse. (Fig. 2)
2. Assemble the ① Gear Rack, ② Left Side Support and ③ Right Side Support on a work bench with the ⑤ Whip Mounts inside the ③ and ⑤ Side Supports. (Fig. 1)
3. Thread in six ⑥ M8x20 Flanged Hex Head Bolts into the ⑤ Whip Mounts. Leave loose for adjustment. (Fig. 1)
4. Loosely attach the ④ Center Support to the bed area. Thread in four ⑨ M6x30 Flanged Hex Head Bolts. Leave loose for adjustment. (Fig. 3 and 4)
Tip: If the bed is dirty, the holes may need to be chased with a M6x1.0 Tap before Step 4.
5. Align the assembly over the bedside mounting holes and then align to the ④ Center Support. Loosely replace the stock button head bolts into the ② Left Side Support and ③ Right Side Support. (Fig. 5)
6. Align the Bed Rack Assembly to the ④ Center Support mounting holes. (Fig. 6)
7. Apply blue thread locker on the two ⑧ M8x20 Button Head Screws and thread them onto the two ⑦ M8 Flanged Hex Nuts. Make any final adjustments and torque the ⑧ M8x20 Button Head Screws to 15Nm (11 ft-lb) (Fig. 6)

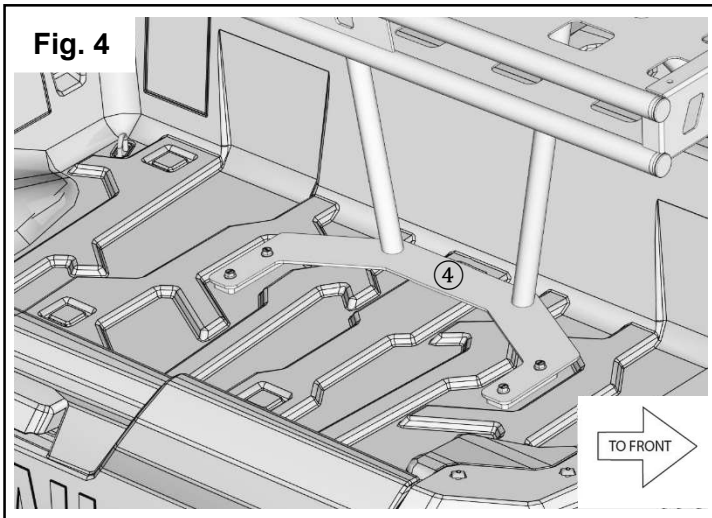

8. Torque the stock bolts in the ② Left Side Support and ③ Right Side Support to 7Nm (5.2 ft-lb). (Fig. 5)
9. Remove each ⑥ M8x20 Flanged Hex Head Bolts one by one and apply blue thread locker. Torque the six ⑥ M8x20 Flanged Hex Head Bolts to 15Nm (11 ft-lb). (Fig. 1)
10. Torque the four ⑨ M6x30 Flanged Hex Head Bolts to 8Nm (5.9 ft-lb). (Fig. 4)
11. Clean the decal locations with alcohol.
12. Peel and apply the ⑩ Pinch Point Decals on each side of the ② and ③ Side Supports. (Fig. 1)

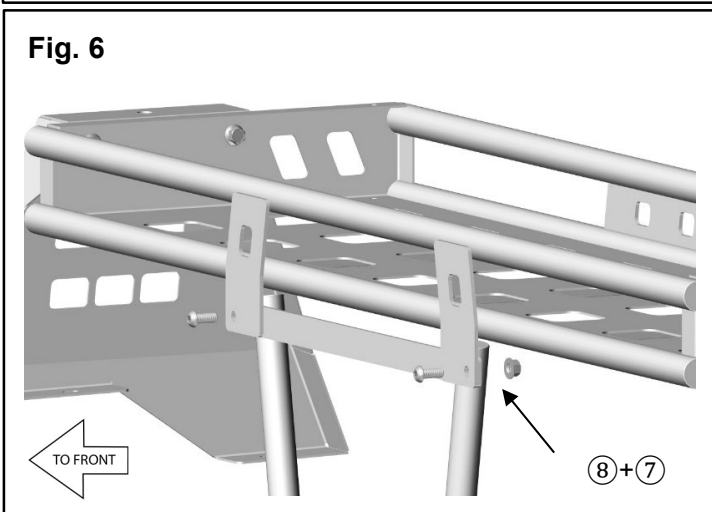
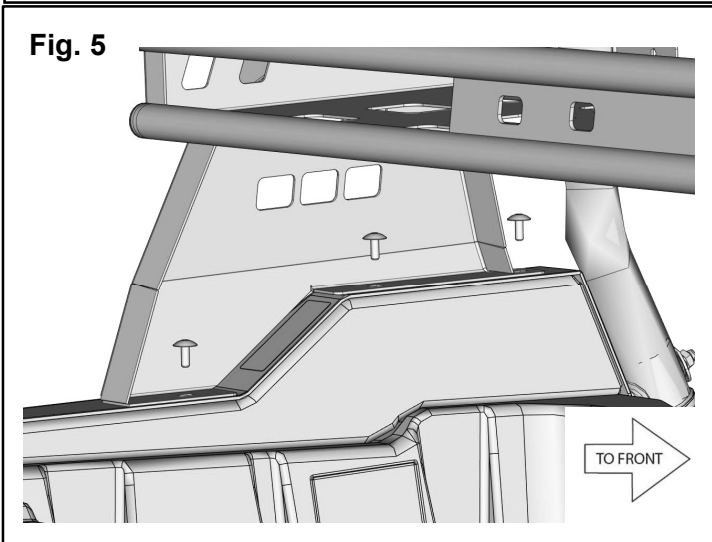

MAINTENANCE:

Periodically, check torque on all hardware. If loose hardware is found, re-torque to specification.

THREAD LOCKING FLUID:

Use Blue Yamabond Threadlocker (LT 271) or similar product that is not a permanent type.

CARE AND CLEANING:

Clean painted metal parts with a clean soft cloth and mild soap and water solution. Rinse and dry.

Bed Rack Kit maximum load is 50 lbs. (22.6 kg) (Cargo and whip flags combined.)

CUSTOMER SERVICE:

For further information see your Yamaha dealer.

ESTIMATED TIME TO INSTALL: 1.0 HRS.